

## MOUNTING INSTRUCTIONS

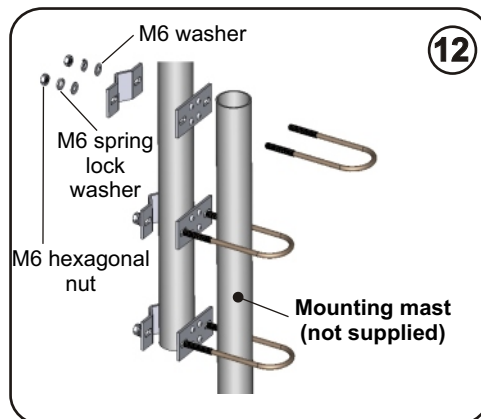
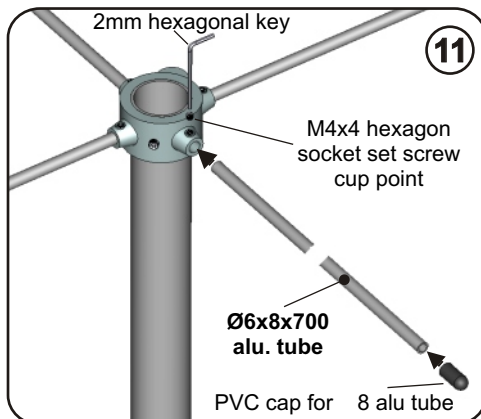
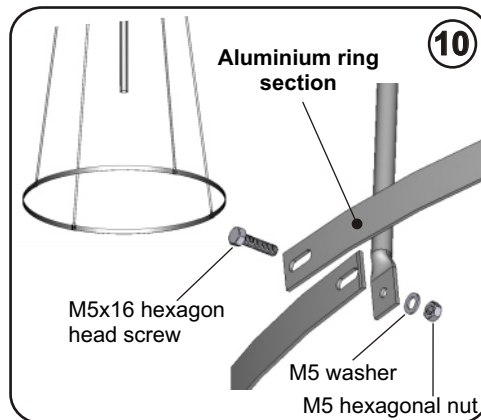
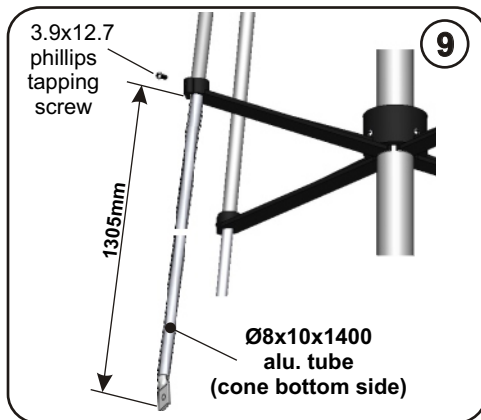
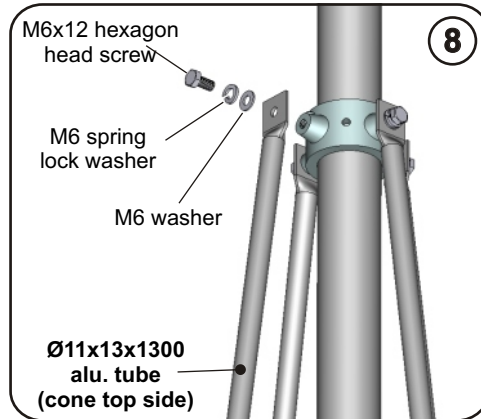
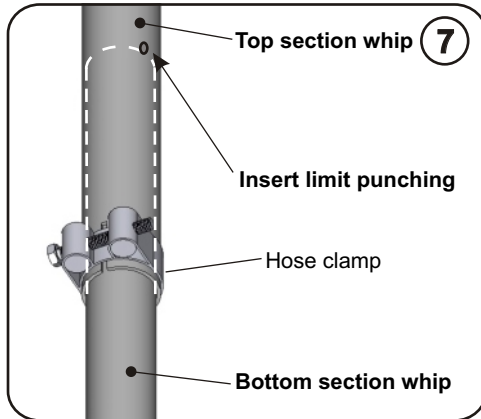

# SIRIO TOP-ONE

## CB & 10m band Base Station Antenna

### DESCRIPTION

Ground plane base station antenna working on CB and 10m band. Made of anti-corodal aluminium tubes. Its robust structure ensure wide band and allows perfect performances and very good connections at long distances too.

### SPECIFICATIONS

#### Electrical Data

Type	: 1/4 Ground plane
Frequency range	: 26.5-28.5 MHz
Impedance	: 50
Radiation (H-plane)	: 360° omnidirectional
Polarization	: Vertical
Gain	: 0 dBd, 2.15 dBi
Bandwidth @ SWR 1.5	: 2000 KHz (180 channel)
SWR @ res. freq.	: 1.1
Max Power	: 1000 Watts continuous 3000 Watts short time
Feed system	: Gamma match
Connector	: UHF-female

#### Mechanical Data

Materials	: Aluminium, Steel, Brass, Nylon
Wind resistance	: 130 Km/h
Length (approx.)	: 3640 mm
Weight (approx.)	: 3900 gr
Mounting Mast	: 35-42 mm

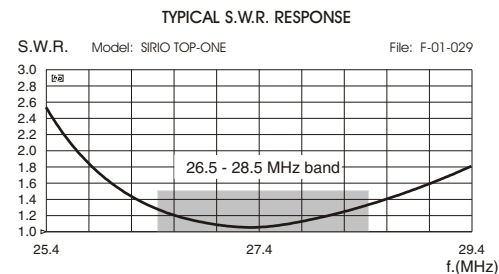

**Mounting needed tools:**

- n. 1 tape rules (meter)
- n. 1 screwdriver cross point
- n. 1 10mm open key
- n. 2 8mm open key

Parts List	
Q.ty	Description
1	Top section whip with connector
6	M5x16 hexagon head screws
6	M5 washer
6	M5 hexagonal nuts
1	gamma match assembly
11	M6 washer
11	M6 spring lock washer
7	M6 hexagonal nuts
1	Bottom section whip with reinforced side
1	36-39mm hose clamp
1	Nylon ring
4	Nylon arms
8	3.9x12.7 tapping screws
1	M6x10 hexagon socket set screw cup point
1	3mm hexagonal key
4	11x13x1300mm alu. tube (cone top side)
	M6x12 hexagon head screws
4	8x10x1400mm alu. tube (cone bottom side)
4	aluminium ring section
4	M4x4 hexagon socket set screw cup point
1	2mm hexagonal key
4	6x8x700mm alu. tube
4	PVC cap for 8 alu tube
3	30x65mm steel "V" bracket
3	30x65mm steel "flat" bracket
3	M6x240mm U-bolt

**REMARK:** use a good coax cable like RG-8 or RG-213 as short as possible to get the best performance and we recommend to mount your antenna as far as possible from metall roofs, walls, power lines and other antennas.

**MOUNTING INSTRUCTIONS**

