

WY 457-6N

VHF Base Station 6 elements Yagi Antennas 457 - 468 MHz

DESCRIPTION: Base station antenna conceived by using an innovative feed system studied and applied to have highly symmetrical radiation pattern in both planes (E and H). It's completely computer designed to get high performances of gain and front-to-back in the working band. All aluminium parts are protected by anodized treatment, hardware are of Stainless steel or zinc plated steel, mounting bracket is of extruded aluminium for the best strength and the connector is placed in rear position for an easily access. To increase the antenna gain please install it in vertical stacked array.

These product is Patented.

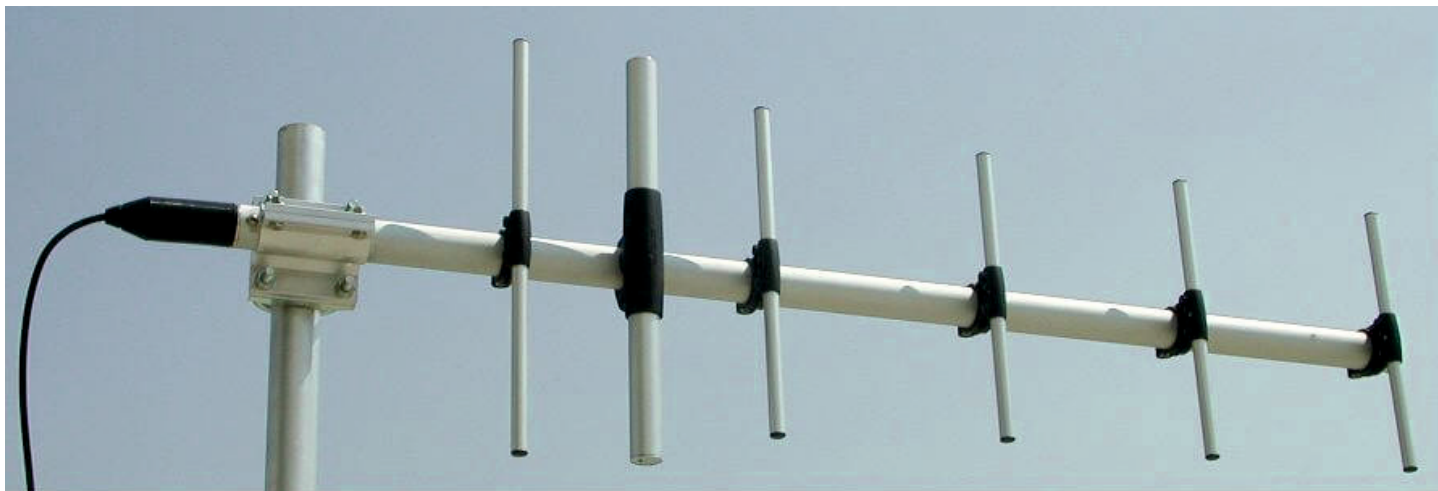

Electrical Data	WY 457-6N
Type	6 elements Yagi
Frequency Range @ SWR ≤ 1.5	457.3 - 467.5 MHz
Impedance	50 Ω
Radiation (H-plane) beamwidth @ -3 dB	58° @ 462.4 MHz - HCM code = 029EB00
Radiation (E-plane) beamwidth @ -3 dB	46° @ 462.4 MHz - HCM = 023EA20
Front to back ratio	≥ 20 dB
Polarization	Linear Vertical or Horizontal
Gain	9.35 dBd - 11.5 dBi
Max Power (CW) @ 30°C	50 Watts (CW)
Grounding Protection	All metal parts are DC-grounded, the inner conductor shows a DC short
Connector	N-female with rubber protection cap

Mechanical Data	
Materials	Anodized 6063-T5 Aluminium, thermoplastic UV stabilized, Chromed Brass
Wind Load @ 150 km/h	76 N
Wind Resistance	150 Km/h; 93 mi/h
Wind Surface	0.06 m ² , 0.61 ft ²
Dimensions W x H (approx.)	1030 x 340 x 80 mm; 40.5 x 13.4 x 3.1 ft
Turning radius (approx.)	950 mm, 37.5 ft
Weight (approx.)	1450 gr; 3.2 lb
Operating temperature	-40 °C to +60 °C
Mounting Mast	∅ 35 - 60 mm; 1.4 - 2.4 in
Boom / Dipole / Element Diameter	∅ 32 mm; 1.3 in / ∅ 24 mm; 0.95 in / ∅ 12 mm; 0.5 in

TYPICAL RADIATION PATTERN in E-plane at 462.4 MHz

File: E-03-042

Scale: logarithmic

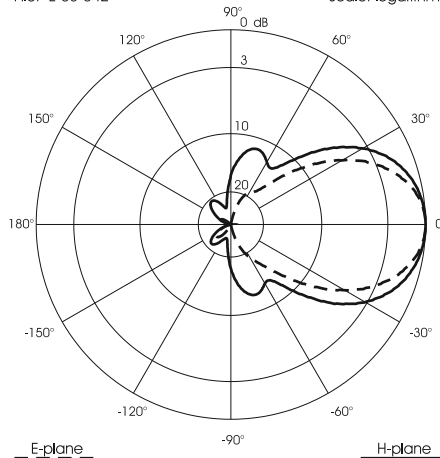

TYPICAL GAIN DIAGRAM vs FREQUENCY

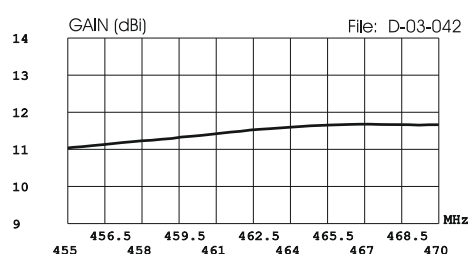

TYPICAL S.W.R. RESPONSE

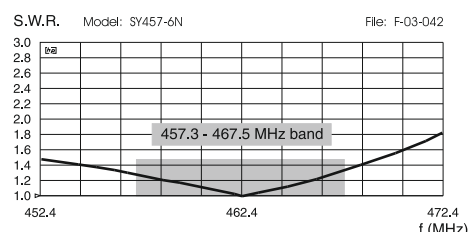

MOUNTING INSTRUCTIONS

**Correct mounting
for horizontal
polarization**

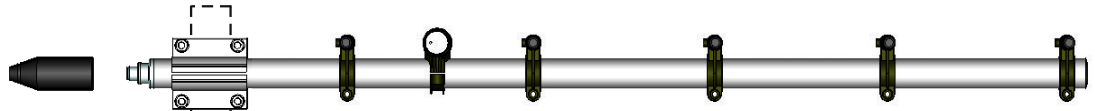

**Correct mounting
for vertical
polarization**

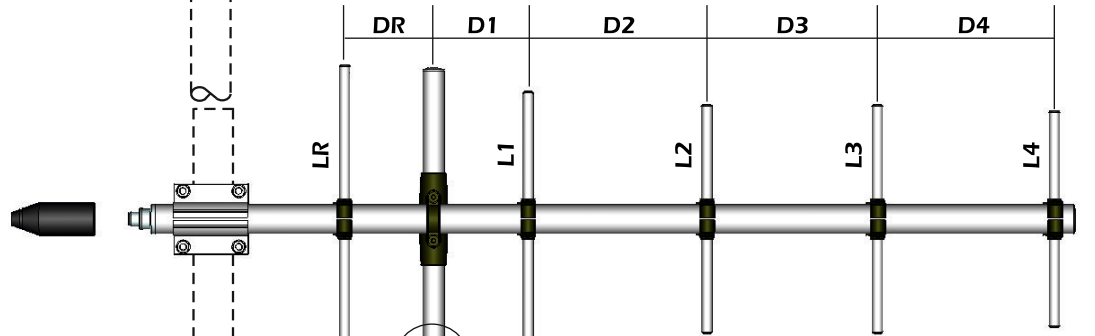

**If mounted for vertical
polarization place the
draining hole at the bottom.**

		LR	L1	L2	L3	L4	DR	D1	D2	D3	D4
WY 457-6N	(mm)	329	271	243	243	230	96	102	193	184	191
	(in)	13.0	10.7	9.6	9.6	9.0	3.8	4.0	7.6	7.2	7.5

Standard FT-6 Mounting Bracket

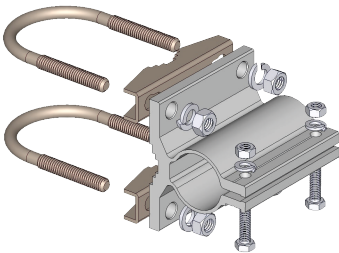

Spare parts: p/n 2519913.00

Materials: extruded aluminum
Hardware: stainless & zinc plated steel
Dimensions : 90 x 85 x 65 mm
Weight: 550 gr

Part list

Q.ty	Description
1	Extruded aluminium bracket
2	Steel bracket
2	M8x216 U-bolt
4	M8 Grower washer
4	M8 Hexagonal nut
2	M6x20 Hexagonal head screw
2	M6 Grower washer
2	M6 Hexagonal nut

Tilting Bracket*

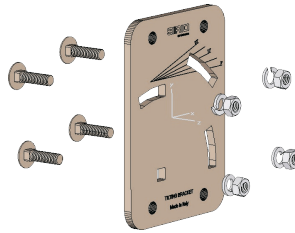

Order p/n: 2519803.00

Materials & Hardware: zinc plated steel
Dimensions: 115 x 155 x 6 mm.
Weight: 800 gr

Part list

Q.ty	Description
1	115x155x6 Tilting bracket
4	M8x25 Spheric head screw
4	M8 Grower washer
4	M8 Hexagonal nut

Mounting example

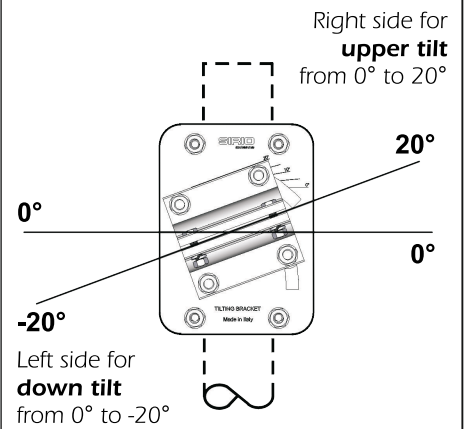

* **Optional (not included).**

Connector protection cap Re-order code: TE06416

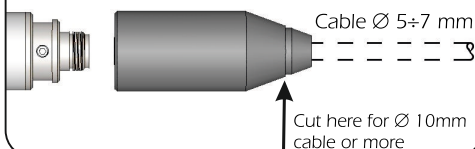

Stacking and Baying distance

L=350mm; 13.8in. S=500mm; 19.7in

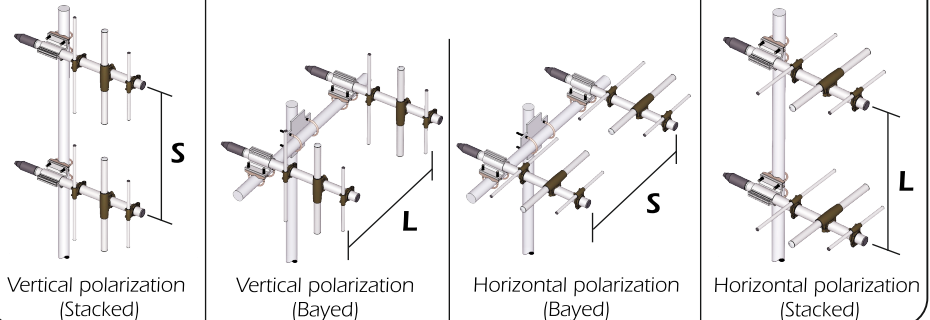

HI-QUALITY ANTENNAS MADE IN ITALY